

Plasma Trimming™ Applications

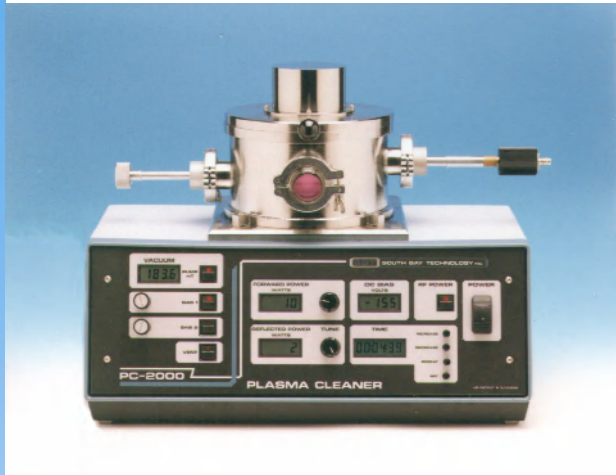

The PC-2000 Plasma Cleaner

In recent years plasma cleaning technology has become a standardized method for preventing and eliminating hydrocarbon contamination from the surfaces of electron microscopy specimens and specimen holders. With the advent of high beam current, high current density electron microscopes, minute amounts of hydrocarbon contamination have become an obstacle during imaging and analysis of specimens, creating thick deposits on the specimen surface which are difficult to remove. The application of reactive and inert gas plasmas has proven to be an excellent method in removing hydrocarbon contamination before it can become deposited onto the

specimen surface. Recent advances have shown that other interesting applications can be applied to traditional methods to enhance specimen throughput and success rate. This paper will describe applications of the Model PC 2000 for Plasma Trimming™.

Plasma Basics

A plasma is an ionized, conductive, gaseous form of matter in which ions, electrons, and neutrals coexist simultaneously. A plasma is generated when a strong electromagnetic field interacts with a reduced pressure gas contained in a specific volume. The field can be produced by DC, RF, or microwave generators with the net effect causing electrons to be removed from the reduced pressure gas near any electrode surface. The electrons are then accelerated by the same imposed field through the remaining gas and loose energy through collisions with other gas molecules, forming a variety of active species including electrons, free radicals, ions and neutral atoms. Plasma generation using RF frequencies operating in the 13.56 MHz range are most commonly

used for low power plasma cleaning and etching processes. Capacitively coupled plasma generation uses an electrode immersed into the working chamber area, with the surrounding chamber walls acting as ground. This electrode, also called the antenna, develops a negative self-bias on it because of the difference in velocities of the gas ions and electrons in the plasma. The value of the self-biasing voltage is dependent on the gas, pressure, geometry, and power. Because the plasma is conductive and has an imbalance of electrons and ions, it has a positive potential associated with it. The energy of the ions are determined by this plasma potential. In the PC-2000, a reactive or inert gas is bled into the chamber at a fixed rate and the chamber volume is pumped down to an operating pressure of approximately 200 mTorr. Increasing the power applied into the system will increase the

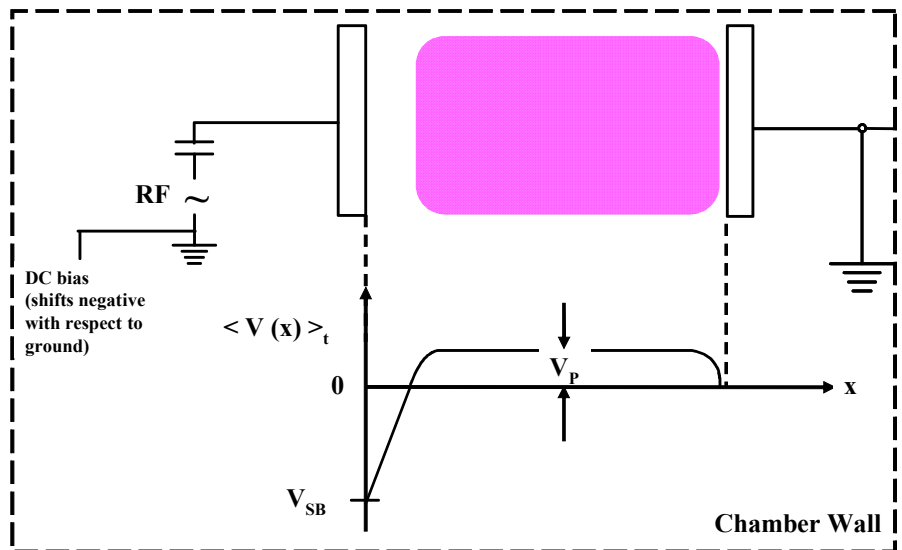

Figure 1 Schematic illustration showing the basic configuration of an RF capacitively coupled plasma generating system with approximate time averaged potential versus distance. (Adapted from Plasma Etching and Reactive Ion Etching, AVS Monograph Series, J.M Coburn)



energy of the gas species generated within the system by increasing the plasma potential. Based on the applied power and chemistry of the plasma/specimen interaction, both specimen cleaning and specimen thinning can occur depending upon the input settings.^{1,2}

Plasma Trimming™

Plasma Trimming™ is a technique by which material is removed from a TEM specimen by use of a moderate energy Ar plasma discharge. By using an Ar gas plasma, the sample can be thinned very, very slowly and in an extremely controlled manner. This allows further thinning of specimens that have been previously ion or FIB milled to remove surface damage, ion milling defects or surface artifacts. The first description of a plasma cleaner affecting an FIB prepared sample was done with a capacitively coupled plasma cleaner supplied by South Bay Technology, Inc.³ In this process, an FIB lift-out sample was held in a TEM holder and Ar was used as the gas because of the damage to the support grid if an oxygen plasma had been used. It was shown that a higher than normal operating power would thin a Zn sample. Since Zn has a high sputter yield compared to any other material except Cd even at low energies, it is not surprising that this sample showed the effects. Quite simply, the plasma potential was high enough so that ions from the plasma striking the sample had enough energy to sputter the Zn. In this application of the technique, if the plasma potential is not high enough, then it will not remove material. There are two problems with this approach. The higher power used to create the higher plasma potential will lead to sputtering from the antenna of a capacitively couple plasma cleaner, which will contaminate the sample. The second problem is that the orientation of the sample relative to the plasma was parallel so that ions struck the surface at normal incidence. Subsequent studies of plasma processing to thin FIB prepared samples utilized this same orientation.^{4,5} Our experiments with biasing a 500 Å gold-coated Si sample to -133 V demonstrated that the normal incidence processing was very slow.⁶ However, this work did demonstrate that the coating near the edges of the sample was removed at a much higher rate. The higher removal rate is due to the increase in the electric field induced at the corners because of the small radius of curvature since the electric field is proportional to the applied voltage and inversely proportional to the radius of curvature. It is this work that suggested the approach for the Plasma Trimmer™. The technique has evolved from the original process discovered by Prenitzer et al.³ to one that uses specialized holders and accessories for the plasma cleaner^{7,8}. In the next sections, the details of the development of the new Plasma Trimming™ technique will be discussed.

Original Plasma Trimming™ Technique

The Ar gas plasma used for this process is a moderate energy discharge creating an isotropic thinning profile. Since Ar is inert, the Plasma Trimming™ is strictly a physical removal process and not a chemical reaction on the specimen. This also means the plasma discharge is non-selective, therefore everything within the chamber is struck by ions of the same energy. In the original technique, the TEM specimen must be “suspended” in the plasma. This could be accomplished using a common ion milling stage, whereby the specimen is supported on the edges and the center open on both the top and bottom. Using the South Bay Technology Model PC-2000 Plasma Cleaner, argon is bled into the working chamber to achieve an operating pressure of approximately 200 mTorr. The system termination timer is set at 10 minutes and the RF discharge started. The system is operated at approximately 75 watts of forward power with the reflected power reduced to the minimum allowable setting. Following termination the specimen thickness can be measured using EELS and the subsequent etch rate can be determined. As discussed above, there are two problems with the technique: the ions are normal to the surface and the energy of the ions is determined solely by the plasma potential. Normal incidence ions will implant the highest amount of surface damage and have a very low removal rate compared to other angular directions. Without special instruments, the

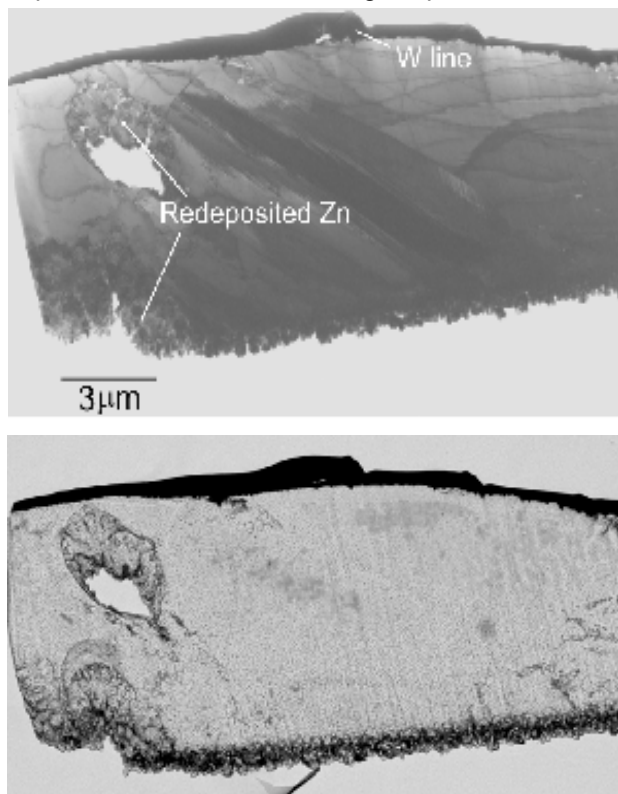

Figure 2 TEM images of a Zn FIB Lift Out specimen. The top image was taken immediately following FIB milling, while the image at the bottom was taken following plasma treatment. Based on the change in image contrast it is clear that the plasma treatment has further thinned the specimen. (Images courtesy B. Prenitzer)



plasma potential is unknown. It is also relatively low and will only be high enough to supply ions with sufficient energy to sputter only a few materials that have a high sputter yield at low energy. Zn is one of those materials and fortunately, it was the material that was examined by Prenitzer et al.³ In their study, an *ex-situ* FIB lift-out sample was processed in the PC-2000 using Ar at a pressure of 200 mTorr, an RF power of 75 watts for 10 minutes. Figure 2 shows the results of that work. The plasma potential was sufficiently high to sputter the Zn portion of the sample and further thin the sample, but it was insufficient to affect the carbon support film. Figure 3 shows the sputter yields for argon at different energies impinging at normal incidence on several selected elements. The yellow shaded portion of the curve represents the energy range that is important for the Plasma Trimming™ process. One can see immediately from the curves that Zn has a high sputter yield even at very low energies compared to any other element. By looking at the Zn and C curves, it is obvious why the Zn sample in the Prenitzer study was thinned while the carbon support film was unaffected. The plasma potential in their study would have been less than 100 V. This would mean that the sputter yield for Zn would be several orders of magnitude higher than that of C with the result that the Zn would be thinned and the C support film would appear to be unaffected.

Argon Sputter Yields

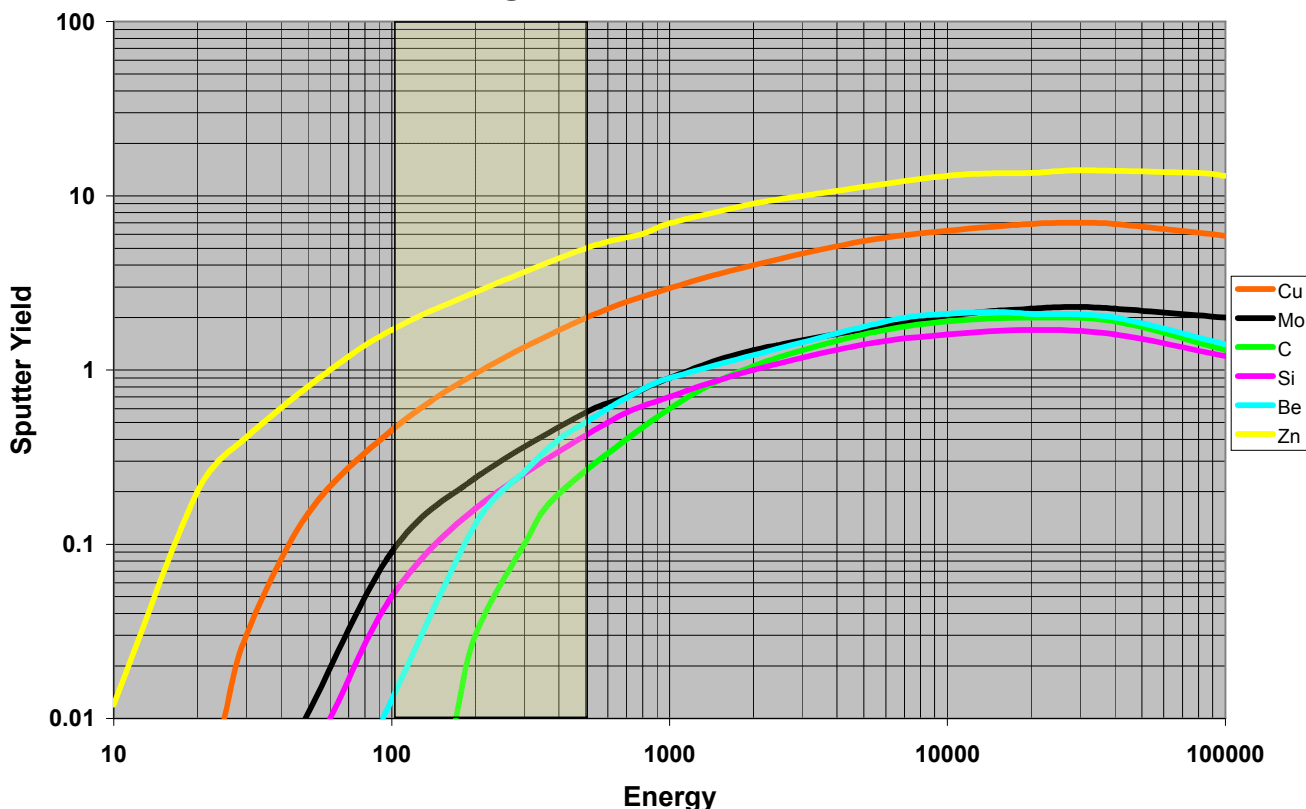

Figure 3 Selected elemental sputter yields at normal incidence. The indicated energy window is representative of the energies that would be used in Plasma Trimming™. (data from American Vacuum Society poster prepared by D.W. Hoffman, T. S. Morley, and J.S. Solomon)

Experiments by Brian Walck as a summer intern in 2005 at SBT were performed to evaluate the effectiveness of the original Plasma Trimming™ technique as applied to other materials. Thin films of Au were deposited on Si and glass substrates to a thickness of 500 Å using the SBT IBS/e ion beam sputter coater system. Gold was chosen because it has a relatively high sputter rate compared to other materials. Its sputter yield curve is almost identical to the Cu curve in Figure 3. Using similar parameters to the Original Plasma Trimming™ in the PC-2000, no apparent thickness changes were seen. These results led us to the conclusion that the original Plasma Trimming™ technique would only be suitable for a few materials and not generally applicable. To increase sputtering the energy of the ions from the plasma would need to be increased and so the samples were biased negatively. Figure 4 shows two examples of biasing the sample with two different RF power levels. In Figure 4A, very little of the central portion of the Au film had been removed. However, evidence of removal in Figure 4B is more readily apparent. But in both cases, an edge effect is clearly seen. Because of the corner of the sample, there is an increased electric field. The electric field is proportional to the applied voltage and inversely proportional to the radius of curvature at the edge. This effect is clearly the result of the increased electric field at

the edges deflecting the ions coming from the plasma and striking the sample at an angle giving an increased sputter removal rate.

RIE Experiments

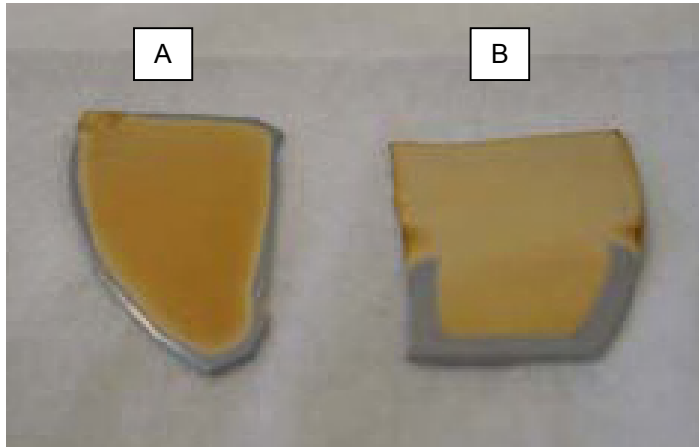

Figure 4 A) 90 watts, 115 mTorr Ar, external bias of -100V. B) 60 watts, 175 mTorr Ar, external bias of -133 volts with a mask on top portion.

The edge effect for increased removal rate of material was then verified using the SBT RIE-3000 system. In a reactive ion etching (RIE) system, the sample sits on the antenna of the capacitively coupled RF system. As shown in Figure 1, the antenna develops a negative bias and will extract ions from the plasma at an energy determined by the difference in the plasma potential and the self-bias potential. As shown in Figure 5, samples of a semiconductor device were held in the flat position and a vertical position using a paperclip in the RIE-3000 and were processed using various power values. The color changes in the vertically oriented samples indicate the significant change in thickness compared to the flat and the untreated samples. The gradient in color indicates higher sputtering at the edges.

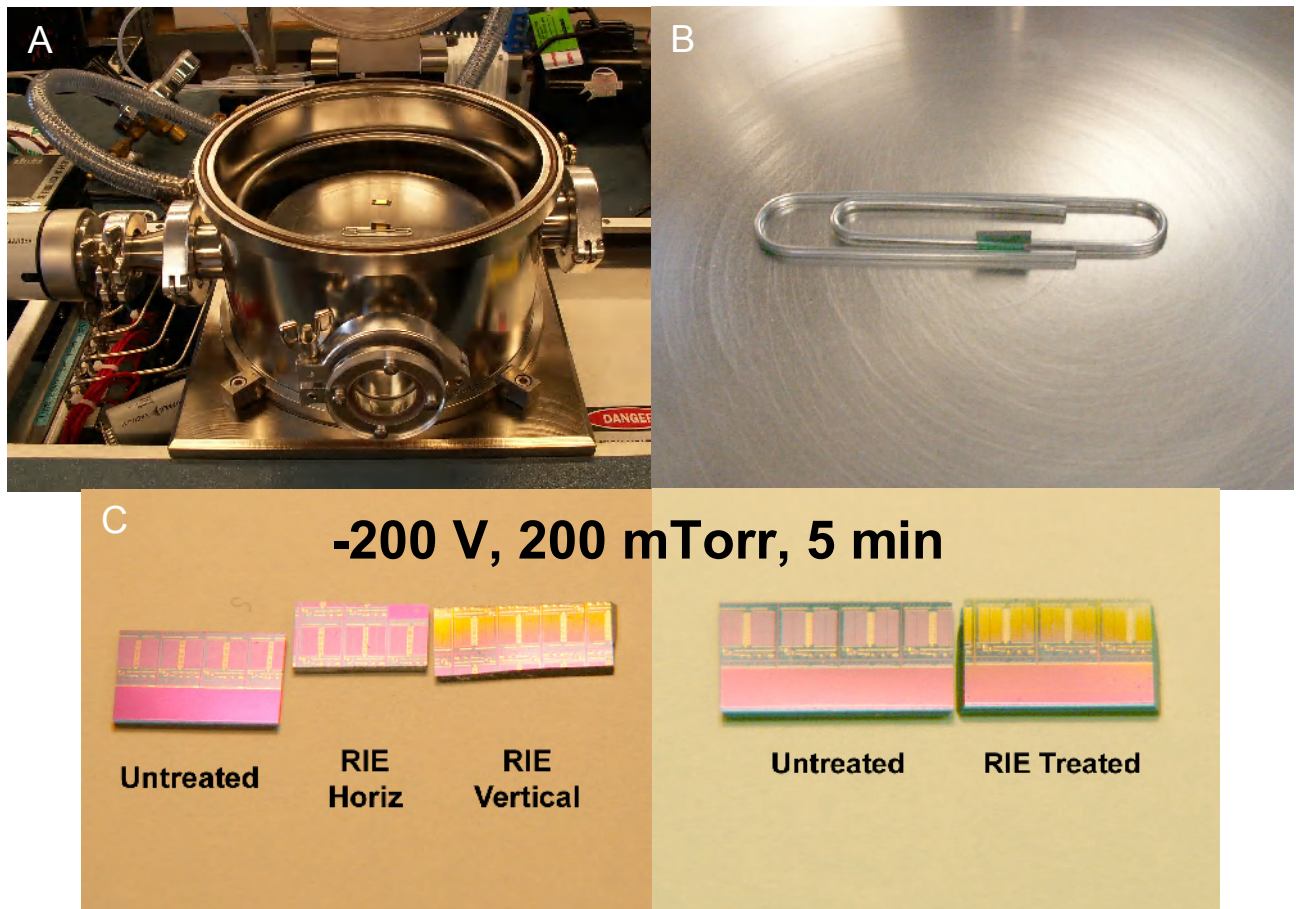

Figure 5 Arrangement for RIE experiments to show edge effects of ion sputtering. A) The system shown is a South Bay Technology, Inc. RIE-3000. B) The samples were simply held in a vertical orientation with a paperclip. C) Two examples of samples processed with the parameters given. The -200V is the displayed dc bias value on the RIE-3000.

Figure 6 is a schematic diagram representing the equipotential lines in a RIE system modified by the presence of a vertical conducting sample. Far from the sample, the equipotential lines are parallel and the field is constant. Close to the sample, the equipotential lines are bent around the sample. Where the equipotential lines are the



closest, i.e. the highest gradient, the electric field is the highest. The electric field will deflect the trajectory of the ions extracted from the plasma. The energy of the ions is determined by the difference in the plasma potential and the sample potential. For the RIE system, the sample potential is given by the dc bias or the self-biasing voltage, V_{SB} , on the antenna as indicated in Figure 1. The angle that the ions will strike the sample is determined by how much they are deflected by the electric fields. Figure 7 shows the Ar sputtering rate for Si relative to the sputtering rate at normal incidence as a function of the ion beam angle of incidence measured from normal incidence.⁹ For the sample illustrated in Figure 6, there will be a continuum of ions angles along the face of the sample. This is the reason that there is a gradient in the color changes that indicate thickness changes for the sample ion processed in Figure 5.

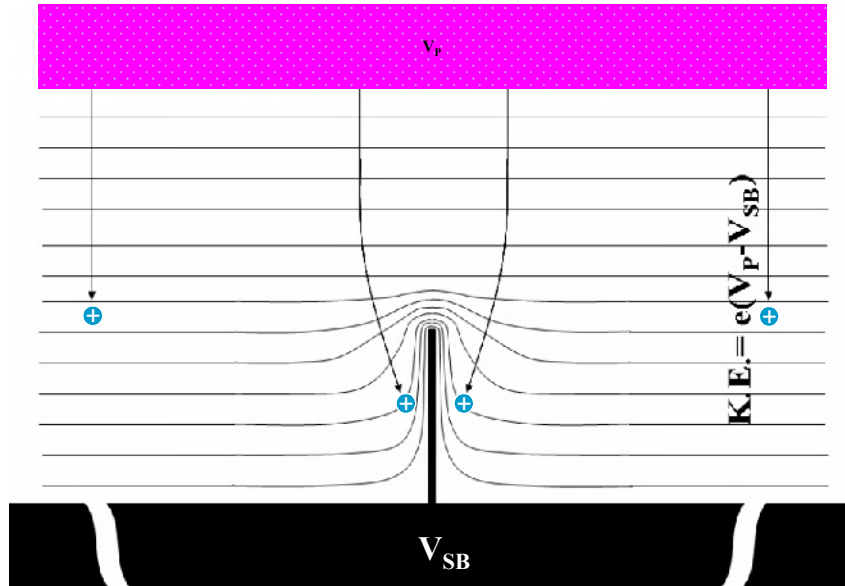

Figure 6 Schematic diagram of the equipotential lines and the trajectory of ions from the plasma bent by the electric field where the gradient in the potential is the highest.

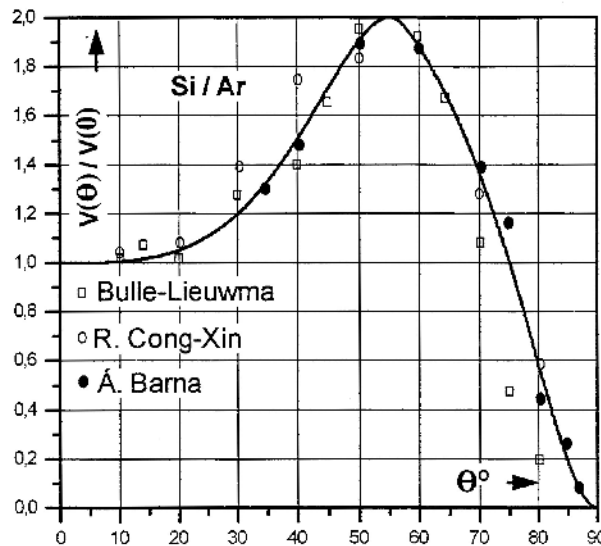

Figure 7 Sputtering rate relative to the sputtering rate at normal incidence as a function of the ion beam angle of incidence measured from normal incidence.

Plasma Trimming™ Instruments

A TEM sample prepared by FIB has the ideal geometry for exploiting the effects that were seen here. The membrane has a very small radius of curvature along the top of the sample. The protective layer on the top protects it from ions that are head-on. The low ion energy will remove the damage region on the top and bottom



surface of the sample that degrades the image. The geometry of an H-bar cut sample is shown in Figure 8 with the evidence of the ion damage present in the images. The bright field image shows a characteristic "salt and pepper" structure, while the high resolution image shows the mottled background superimposed on the atomic structure. The intentional cut shows that the damage depth for each surface can be as much as 240 Å. If the FIB sample can be held in a vertical position relative to the plasma and biased, the rate of removal of material at the low energy will be faster than that if it were simply held in a horizontal mode where the ions are striking the surface at normal incidence.

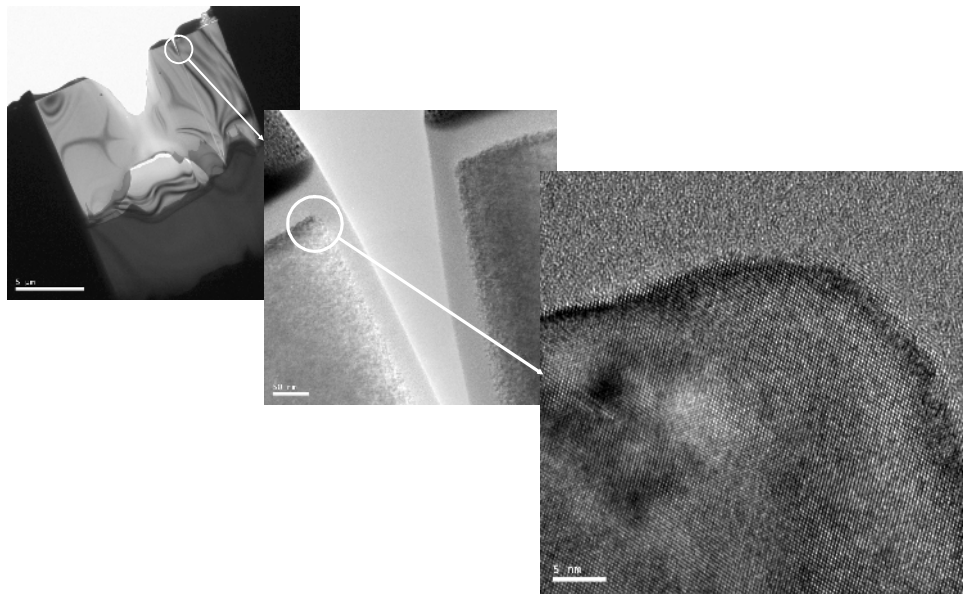

Figure 8 The geometry of an FIB H-bar cut TEM sample. The amorphous damage from FIB thinning can be greater than 240 Å on each surface when using 30 keV Ga⁺ as evidenced here by the circled, intentional cut.

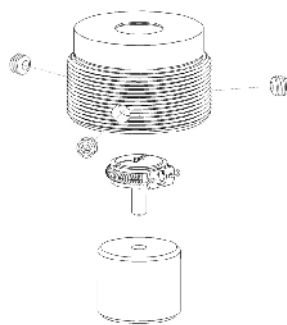
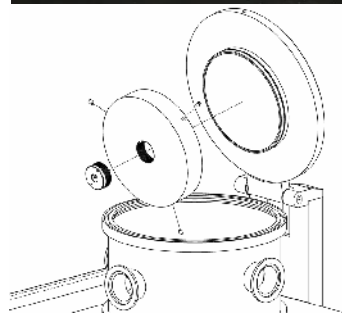

Figure 9 Model PCPT Plasma Trimmer™. The holder is a modified Fortress™ holder and the flat surface exposed to the plasma is painted with graphite paint.

Two Plasma Trimming™ instruments were developed, the model PCPT Plasma Trimmer™, and the model PTR-2000 Plasma Trimming™ rod. The PCPT is designed to attach to the antenna of the PC2000 plasma cleaner. The voltage is applied by the self biasing of the antenna. The PTR-2000 is designed to use an external programmable power supply and can be used with any commercially available plasma cleaner. The two units are shown in Figure 9 and Figure 10. The PC2000 can operate with the antenna self-biased to -1000 Vdc at which point it is clipped. For the PCPT, the voltage is set by adjusting the power setting and the pressure. Typically, the unit is run at 200 mTorr and so the voltage is set solely by adjusting the RF power. The maximum voltage that can be supplied with the programmable power supply of the PTR-2000 is -500V. In both instruments, a modified Fortress™ holder holds the sample in the upright position. A schematic diagram of this holder is shown in Figure 11 holding an Omniprobe grid. To prevent material from the holder from being sputtered onto the sample, the surface of the holder perpendicular to the sample is coated with graphite paint.





Figure 10 Model PTR-2000 Plasma Trimming™ Rod system. The PTR-2000 uses the same modified Fortress™ holder as the model PCPT. The programmable power supply can be programmed with up to four steps from 0 to -500V for 1 s to 24 hr.

Electrostatic simulations were performed to determine the equipotential and electric field distribution around an FIB prepared H-bar cut TEM sample while a potential of -500 V was applied. Some results are shown in Figure 12. The calculations assume a potential difference of 500 V between the plasma and the antenna and a gap of 1 cm, a 25 μm thick grid that sticks up for 250 μm , a 15 μm thick sample that sticks up 230 μm from the grid and then a 0.010 μm thick FIB'd region that is 20 μm high. Where the equipotential lines are parallel, i.e. far from the sample, the electric field strength is constant at $5.0 \times 10^{+4}$ V/m (500 V/cm). The electrostatic field simulation for a FIB-thinned sample shows a significant increase in the electric fields near the apex of the sample. These high electric fields will bend the ions towards this area more strongly. The field lines along the side of the sample are less strong and the ions will arrive at those surfaces at a shallower angle.

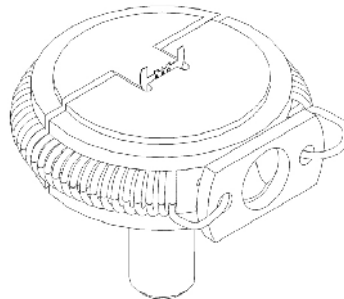
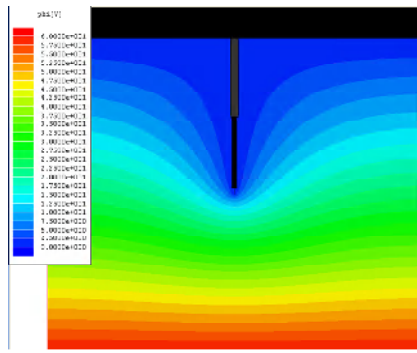
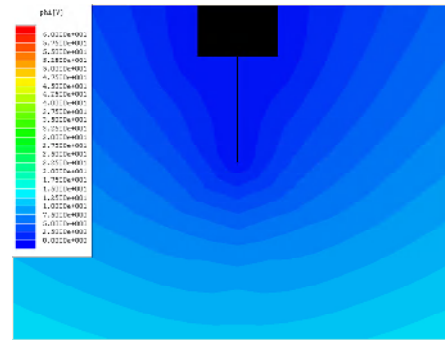

Figure 11 Schematic illustration of a modified Fortress™ holder with an Omniprobe grid holding a FIB-prepared sample in a vertical orientation.





**Equipotentials –
Zoomed Out**



**Equipotentials –
Zoomed In**

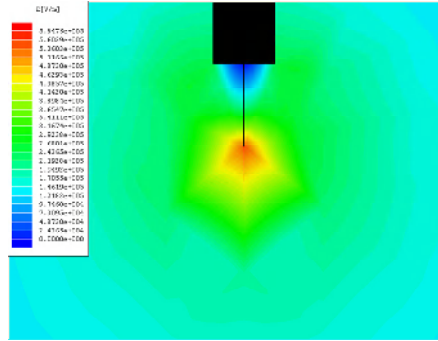

**Electric Field Strength
Map – Zoomed Out**

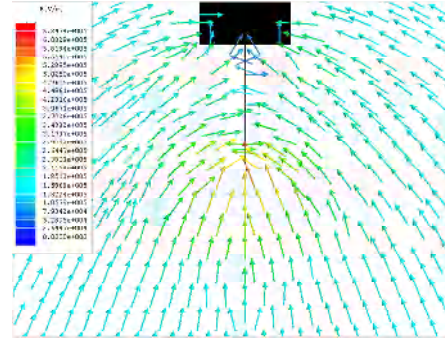

**Electric Field Map –
Zoomed In**

Figure 12 Electrostatic simulations of the equipotential and electric field of an FIB H-bar cut TEM sample with a voltage of -500 V applied.

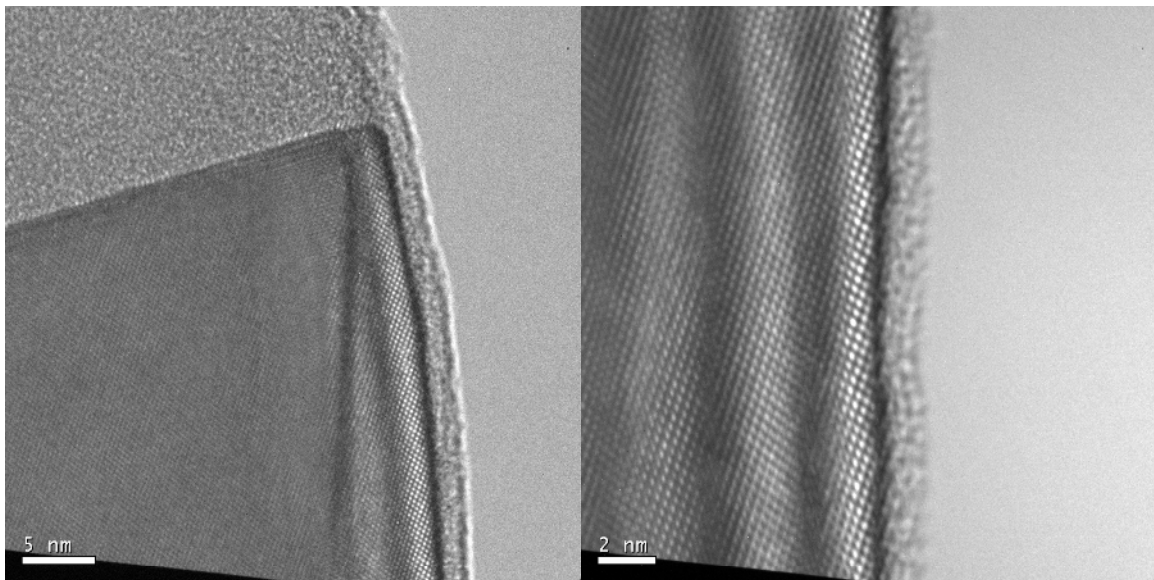

Figure 13 High resolution images from the sample shown in Figure 8 after processing with the model Plasma Trimmer™ for 60 min, 200 V, 20 Watts, 200 mTorr and then 60 min, 100 V, 10 Watts, 200 mTorr.



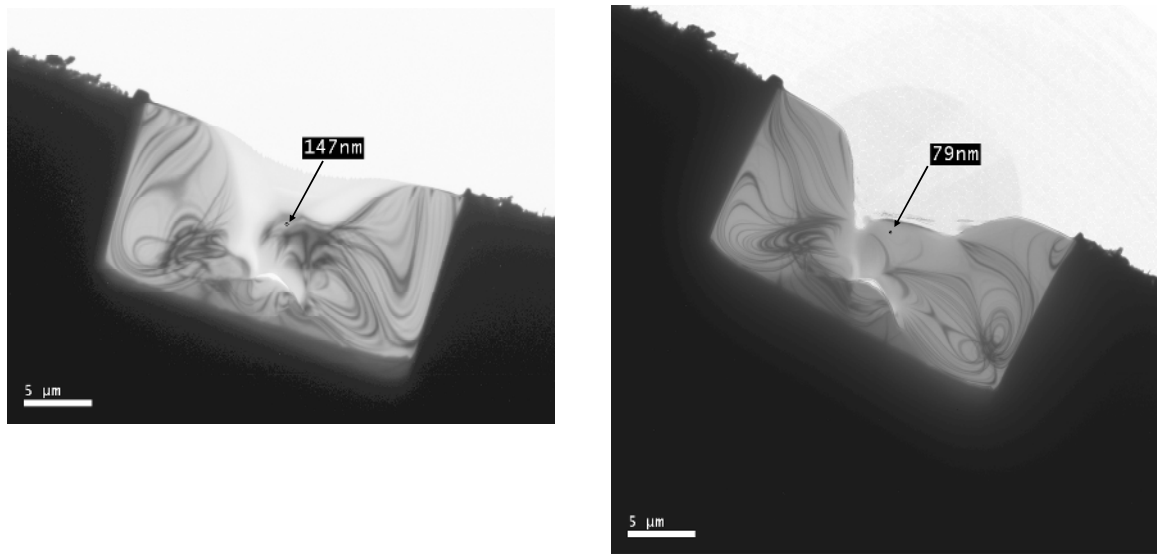

Figure 14 Plasma Trimming™ results for an FIB prepared Si sample after 10 min processing using the Plasma Trimmer™ at a dc bias of -500V. The value of the thickness at the point was measured using EELS.

The thinning rate can be measured using EELS. Figure 14 shows the results for Plasma Trimming™ a FIB-cut H-bar silicon sample at -500 V for 10 minutes using the PCPT. In the middle of the sample, you can see where the two amorphous surface regions have met and it is completely amorphous through the thickness of the sample in that region. The point indicates where the EELS thickness measurement was found to be 147 nm. After processing, it can be seen that the amorphous region was removed. The same point was again measured and a thickness of 79 nm was determined. This gives a thinning rate of 6.8 nm/min. It should be noted that the rate closer to the surface is higher. An interesting observation is that even the un-cut areas of this sample shows evidence of thinning. The regions adjacent to the membrane in the plasma trimmed area have also been thinned. This suggests that the technique may be useful for thinning very thick samples to electron transparency. In Figure 15, a bias of -212 V was used for 10 min and a thinning rate of 0.6 nm/min was measured. The EELS and XEDS data also showed that there was no C or Al deposited in the thinned area that could have been sputtered onto the sample. These results show that an appropriate preparation process to remove ion processing damage would be to start at the higher bias voltage and then the finish a lower value. The 10 min treatment at -500 V would have removed all of the FIB damage from a 30 keV instrument (approximately 240 Å per side) and thinned the crystalline portion as well. The subsequent processing at -200 V would have removed the Ar damage from the Plasma Trimming™ at -500 V.

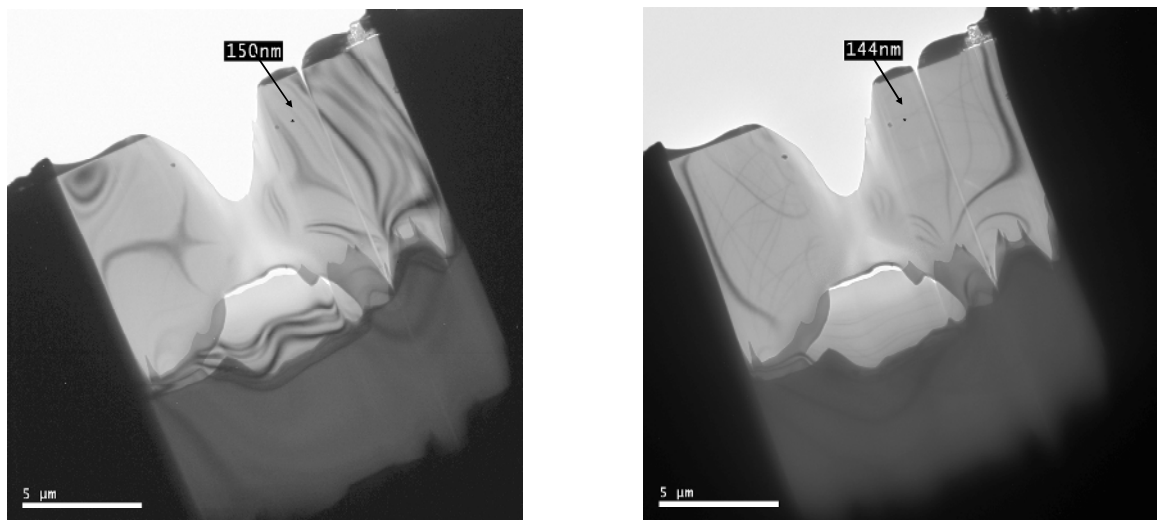

Figure 15 Plasma Trimming™ results for an FIB prepared Si sample after 10 min processing using the Plasma Trimmer™ at a dc bias of -212V. The value of the thickness at the point was measured using EELS.

The antenna adapter plate, sample holder, and receptacle of the PCPT are made from aluminum. When the bias voltage is high enough to sputter material, the aluminum is sputtered as well. The distribution of sputtered

material when the ions are normal to the surface is in a cosine distribution. The surface of the receptacle is raised relative the antenna adapter plate so that there is no direct line-of-sight from anywhere on the adapter plate to the sample. This will prevent material from the adapter plate from being sputtered onto the sample during Plasma Trimming™. However, the sample holder and receptacle are not shielded. This is also the case for the sample holder when it is held in the PTR-2000. Carbon has a very low ion sputter rate with argon. By covering the surfaces of the receptacle and the sample holder with carbon paint, the removal rate of material from the sample is much higher than any carbon sputtered onto the sample and no detectable amount of carbon will be deposited. However, the grid material is capable of sputtering onto the sample. Lift-out FIB samples, shown in Figure 16 and Figure 17, are particularly sensitive to this problem. Several things can be done to avoid this problem:

1. Weld the lift-out sample close to the top of the grid, but off to the side. The configuration of the sample on the left in Figure 16 is preferable to the configuration shown in Figure 17.
2. Grids made of Mo are preferable to grids made of Cu. Careful examination of Figure 3 shows that a C and Be grid should also work very well. (Ti, not shown, should also work as well, if not better, than Mo.)
3. Make the thickness of the lift-out sample a little thicker than normal. This sample itself will then help shield the thin area from the sputtered grid material.
4. A heavy carbon coating on the grids prior to attaching them will help avoid contamination by the grids.

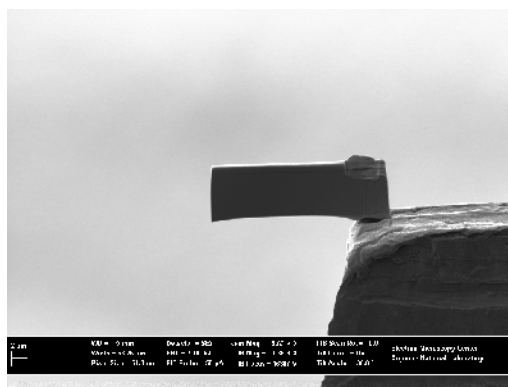
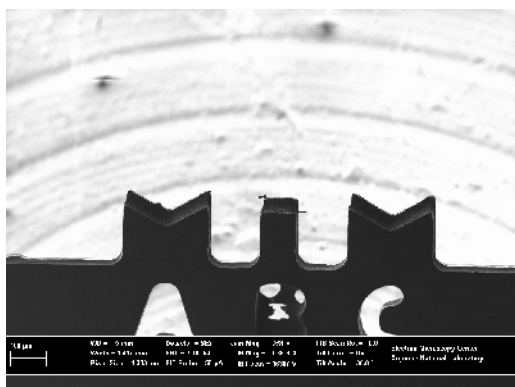

Figure 16 SEM images of actual lift-out samples mounted on an Omniprobe grid held in a Fortress™ holder.

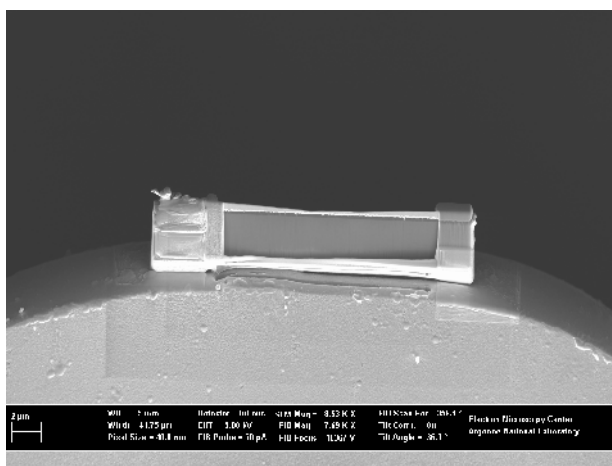

Figure 17 Avoid this arrangement of attaching the lift-out sample.

Figure 18 shows the sample in Figure 17 after extensive Plasma Trimming™. The sample is a silicon substrate with a coating of an ultra-nanocrystalline diamond coating with a layer of gold on top.* The Plasma Trimming™ process schedule for the sample is given in Table 1. Initially the sample is thinned, but then the EELS thickness

* Images and data courtesy of Nestor Zaluzec, John Hiller, and Dean Miller from the Electron Microscopy Center at Argonne National Laboratory.

data indicates that the sample is getting thicker. At higher magnification, small islands of copper are seen decorating the surface from being sputtered from the copper grid. Mounting the sample on a Mo grid on the side of the Omniprobe grid would have prevented this from happening. The sequence of thickness map images and indicated line profiles for the schedule in Table 1 are shown in Figure 19. This sequence of images also shows the higher removal rate at the surface of the sample compared to the body. Note the change in the thickness of the protective Pt layer as the sequence goes from T0 to T3. This is also seen in the width of the line profiles of the Pt_{FIB} protective layer in the line profiles.

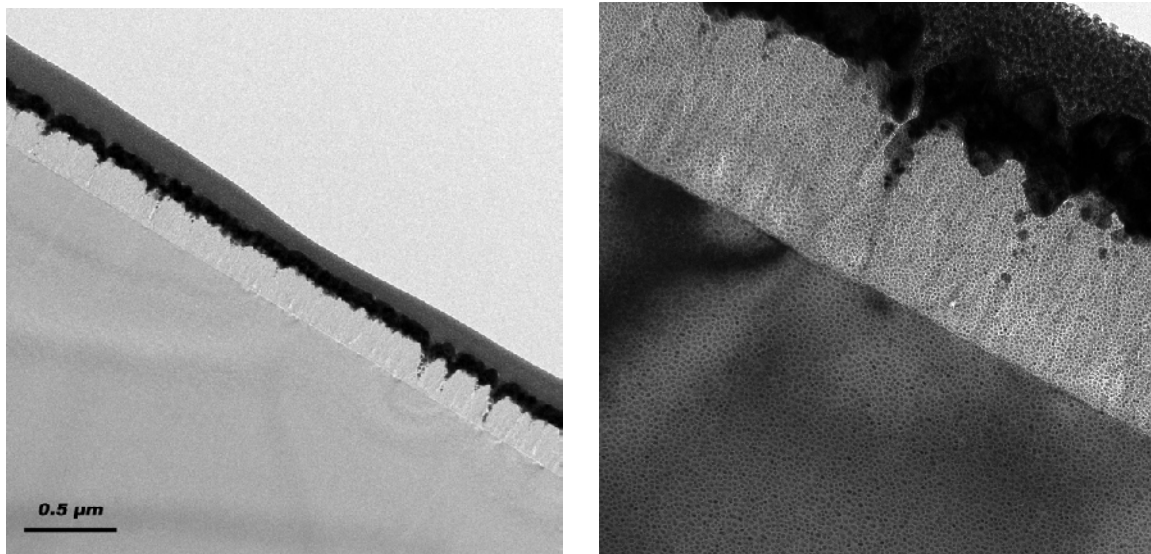

Figure 18 Example of the sample in Figure 17 after extended Plasma Trimming™. Copper has been deposited onto the sample from the copper grid.

Table 1
Plasma Trimming™ Schedule

Treatment Step	Pressure	Process
T0	200 mTorr	As FIB'd
T1	200 mTorr	40 W, -250 V 10 min 20 W, -130 V 10 min
T2	200 mTorr	(40 W, -250 V 10 min, 5 min off) x2 20 W, -130 V 10 min
T3	200 mTorr	(40 W, -250 V 10 min, 5 min off) x2 20 W, -130 V 5 min

Figure 20 shows the results for a Plasma Trimmed™ semiconductor device. This sample was relatively very thick. After Plasma Trimming™, the sample was significantly thinner, but was still relatively thick for TEM observation. However, this sample vividly demonstrates the removal of the Ga⁺ damage in the Al layer. The Plasma Trimming™ conditions were - 500 Volts for 20 min using a 5 min on and 5 min off duty cycle, followed by - 200 V for 30 min continuous duration all at a pressure of 200 mTorr. The sample was an *in-situ* lift-out sample mounted on a Mo Omniprobe grid. No C or Al deposition was detected.

Summary

The Plasma Trimming™ technique is a viable method for eliminating the ion damage from FIB processed samples. It is also capable of further thinning the sample. The low energy processing can give nearly damage-free samples. It will also clean the native oxide from samples. It is performed with the same sample holder that is used for FIB processing and so can save time. The geometry of Tripod Polished samples are aptly suited for this technique and could eliminate the need for an ion mill for those types of samples. In addition, the sample holders that are used are compatible with the SBT SampleSaver™ storage containers and can safely store and transport samples in an inert atmosphere.



EELS Thickness Maps

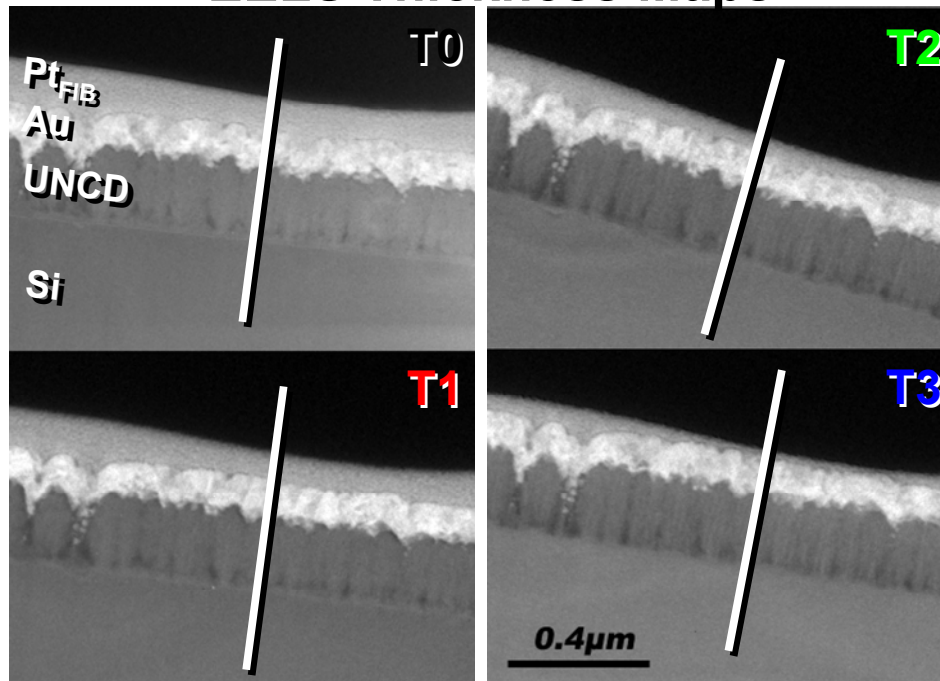

EELS Thickness Map Line Traces

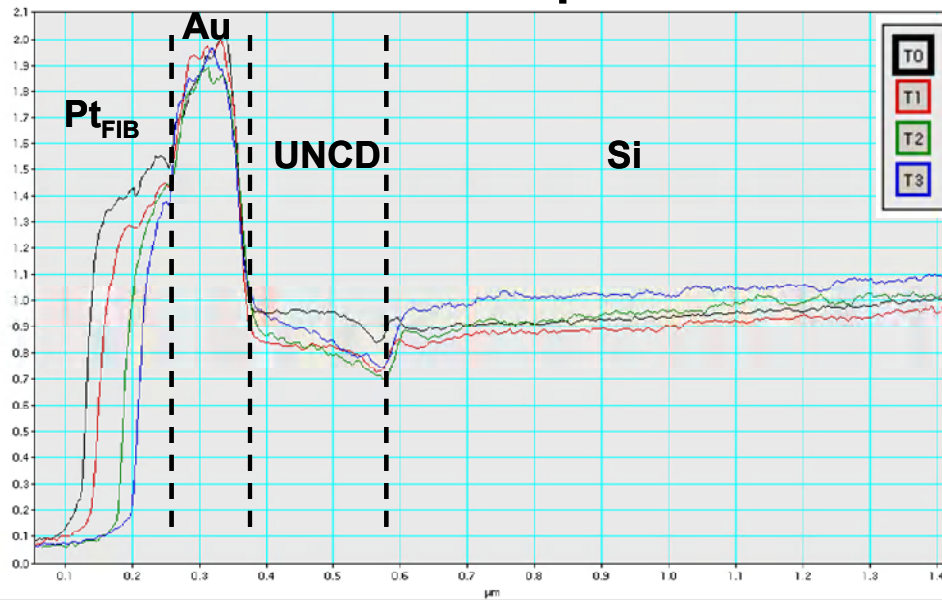

Figure 19 Sequence of EELS Thickness images and corresponding line traces after the Plasma Trimming™ steps given in Table 1.



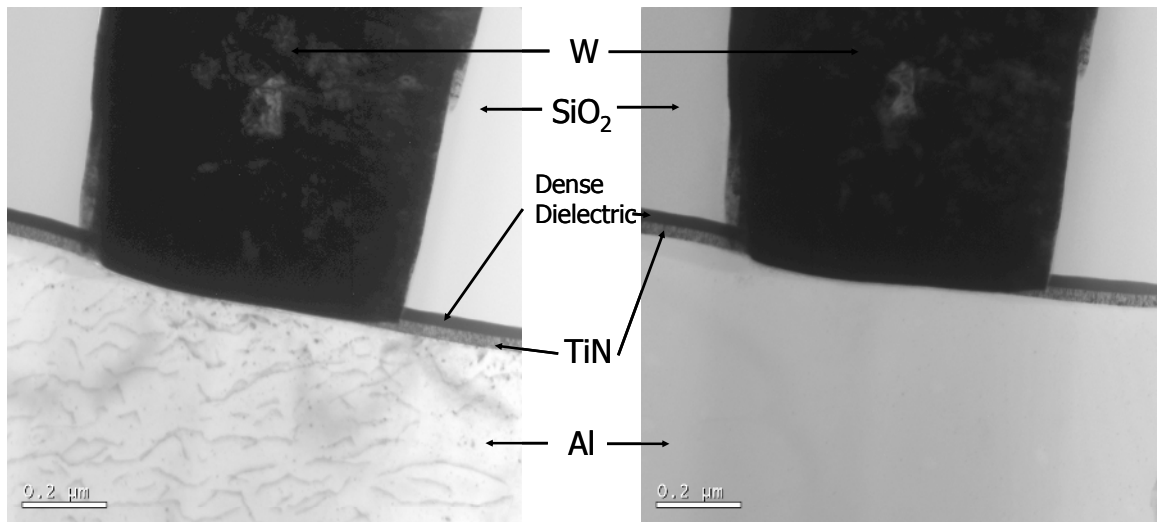

Figure 20 A very thick FIB-prepared semiconductor device. Thinning of the device occurred as well as the removal of the Ga⁺ damage from the Al layer.

References

1. N. Zaluzec, *Plasma Processing of Specimens for Electron Microscopy and Microanalysis*; 1999.
2. S. Roberts; S. Walck; N. Zaluzec; J. Grant, *Application of Reactive Gas Plasma Cleaning in Mitigating Contamination of Specimens During TEM and AEM*, *MRS Vol. 480*, 1997.
3. B. Prenitzer, S. Collins, L. Gianuzzi, *In Situ Transformation of a Zinc TEM Lift-Out Specimen*, *Microsc. Microanal.* **5** (Supp 2), pp 928-929, 1999.
4. S. Hata, H. Sosiati, N. Kuwano, M. Itakura¹, T. Nakano, and Y. Umakoshi, *Removing Focused Ion-Beam Damages on Transmission Electron Microscopy Specimens by Using a Plasma Cleaner*, *J. Elect. Microsc.*, **55**(1), pp23-26, 2006.
5. D-S Ko, Y. M. Park, S-D Kim, Y-W Kim, *Removal of Surface Damage from Focused Ion Beam using Plasma Cleaner*, *Microsc. Microanal.* **12**(Supp 2), pp 1262-1263(CD), 2006.
6. B. Walck, *Plasma Trimming Experiments*, South Bay Technology, Inc. Summer Intern Report, 2005.
7. Effect of Geometry, Bias, and Materials Selection for Controlled Plasma Trimming™ of FIB Prepared TEM Samples, S. D. Walck, J. L. Lehman, J. M. Hiller, D. J. Miller, C. Tirrell, P. Carter, C. C. Broadbridge, M. Enjalran, *Microscopy and Microanalysis 2007*, Ft. Lauderdale, (2007) (presentation).
8. Sample Preparation Considerations for Electron Microscopy Characterization of Nano-Materials, S. D. Walck, *Microscopy and Microanalysis*, **14**, (supp. 2), pp. 382-3, (2008).
9. A. Barna, B. Pecz; *Topographic Kinetics and Practice of Low Angle Ion Beam Thinning*; *Mat. Res. Soc. Proc.*, Vol. 254, p. 7, 1992.